



**[www.RedMountainRadio.com](http://www.RedMountainRadio.com)**

Thanks for your interest in my technical paper. If you find this work to be interesting, or have additional questions, please contact me at the address below. Red Mountain Radio LLC offers professional RF, optical, and microwave design services, and problem solving.

Regards,  
Eric Funk, Ph. D.  
Partner, Red Mountain Radio LLC  
[eric@redmountainradio.com](mailto:eric@redmountainradio.com)  
970-325-2158 x12

The following IEEE paper is subject to copyright as noted below.

This material is presented to ensure timely dissemination of scholarly and technical work. Copyright and all rights therein are retained by authors or by other copyright holders. All persons copying this information are expected to adhere to the terms and constraints invoked by each author's copyright. In most cases, these works may not be reposted without the explicit permission of the copyright holder.

©1993 IEEE. Personal use of this material is permitted. However, permission to reprint/republish this material for advertising or promotional purposes or for creating new collective works for resale or redistribution to servers or lists, or to reuse any copyrighted component of this work in other works must be obtained from IEEE."

# PHOTOCONDUCTIVITY QUENCHING IN A GaAs OPENING SWITCH PULSED POWER SYSTEM

E. E. Funk and Chi H. Lee

Department of Electrical Engineering  
University of Maryland  
College Park, MD 20742

L. Jasper Jr.

Army Research Laboratory  
2800 Powder Mill Road  
Adelphi, MD 20783

## Abstract

The use of a GaAs photoconductive closing and opening switch in an inductive energy storage system has, in the past, required a custom built laser with optical pulse shaping. We now describe a system which may be operated by a simple, Q-switched laser pulse. We have designed a high impedance (500- $\Omega$ ) system which provides a switch conduction time which is sustained longer than the laser pulse. Furthermore we have demonstrated that at high voltages the switch exhibits fast quenching of conductivity resulting in opening times of less than 20-ns after sustained conduction. This fast opening action has allowed us to achieve a power gain of up to 8.9 and switched out voltages as high as 7-kV.

## Introduction

Inductive energy storage pulse power systems (IESPPS's) store energy in an inductor or transmission line. Inductive energy storage densities can be much higher than capacitive energy storage densities, hence, they are more compact. These systems are also capable of providing voltage step-up with a gain in peak power. The key element in an IESPPS is the *opening* switch. In the past<sup>1,2</sup> we have shown how the GaAs photoconductive switch (PCS) could function as an almost ideal opening switch in an IESPPS with a switched out voltage of 2.1-kV and a power step-up of 45.

In this work we outline some improvements on the IESPPS used previously which have allowed us to reach an output voltage of 7-kV with power gain. Our IESPPS is an improvement of the current charged transmission line<sup>3</sup> (CCTL) circuit shown in Fig. 1. The switch in the CCTL circuit of Fig. 1 is closed by illumination with a Nd:YAG or Nd:Glass laser pulse. The laser must be operated free running (non Q-switched) in order to produce a long pulse, and that pulse must be chopped into a square pulse via a Pockels Cell and crossed polarizers. While the switch is on, the CCTL is charged with current. The conductivity of the switch follows the shape of the laser pulse. Hence, the long, square optical pulse ensures fast closing and fast opening of the switch with a long switch on-time.

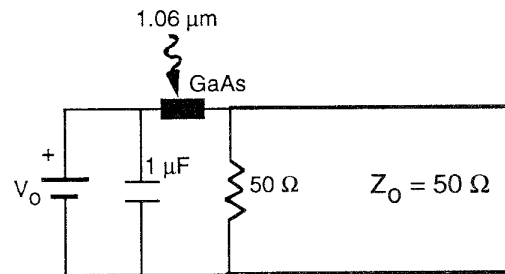

Figure 1. Basic current charged transmission line (CCTL) circuit.

Now we investigate an IESPPS system which requires neither pulse shaping nor a long laser pulse. This improved IESPPS allows the switch to stay closed for a period much longer than the FWHM of an unshaped Q-switched laser pulse which was used as a trigger. The operation of the improved system is based on extending the on-time of the switch by designing a higher impedance system. This allows a short Q-switched pulse to trigger the switch rather than a long pulse. We then observed that if the charging voltage is high enough, the switch spontaneously opens with a fast risetime after a long period of conduction (~90-ns). This mechanism provides the fast opening action which is required. The behavior of the switch at these high fields may be related to the phenomenon labeled "lock-on"<sup>4</sup> in closing switch experiments.

## Extending the switch on-time

In the design of our IESPPS we first consider the long on time requirement. We define the opening time of the GaAs photoconductive switch as the time required after the extinguishing of the laser pulse for the switch to recover from its low-resistance state to a resistance which exceeds the load impedance. Therefore, if we design the system with a 500- $\Omega$  characteristic impedance and a 500- $\Omega$  matched load, the on-time of the switch will be significantly longer than it would be in the 50  $\Omega$  system given the same carrier lifetimes.

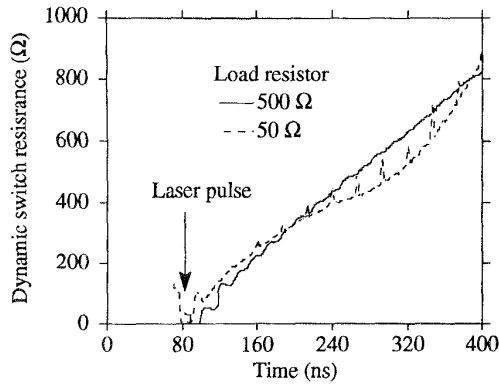

Figure 2. Dynamic switch resistance behavior of the 3-cm long GaAs switch when discharging a capacitor into a 500- $\Omega$  and a 50- $\Omega$  load respectively.

The on-time of a GaAs photoconductive switch was determined with both 50- $\Omega$  and 500- $\Omega$  loads by discharging a 1- $\mu$ F capacitor through the switch and calculating the dynamic switch resistance from the oscilloscope trace taken across the load. The capacitor was initially charged to 5-kV. A 12-ns, 1.06  $\mu$ m, 500 mJ, Q-switched laser pulse was used to trigger the switch. The switch was a 3-cm X 5-mm X 5-mm sample of GaAs. Au:Cr contacts were evaporated on each end, 3-cm apart. The dynamic switch resistance, which was calculated from the oscilloscope trace of current through the load, is shown in Fig. 2. The spikes in the 50- $\Omega$  trace appear as a result of increased sensitivity to noise in the calculation at higher switch resistances.

Notice that, following the laser pulse, the switch resistance rises to 50- $\Omega$  within less than 10-ns. Hence, the switch on-time in the 50- $\Omega$  system is determined by the length of the laser pulse, and we observed that the switched-out wave form follows the shape of the 12-ns FWHM laser pulse. In the case of the 500- $\Omega$  system, the switch must reach at least 500- $\Omega$  before being considered "opened". Since more than 150-ns are required to reach 500- $\Omega$ , the switch remains "on" long after the 12-ns laser pulse.

#### Pulsed Power System: Theory

The increased amount of time during which the switch is closed in the 500- $\Omega$  system has been exploited by the design of a transmission line IESPPS with a 500- $\Omega$  matched load. This improved IESPPS circuit is shown in Fig. 3. Ten 50- $\Omega$  current charged transmission lines (CCTL's) wired in series<sup>5</sup> with floating shields are used rather than a single 500- $\Omega$  CCTL. With this design, the Q-switched laser pulse described above can be used to trigger the switch without pulse shaping. In this system, the switch on-resistance must reach 250- $\Omega$  in order for the switch to become "opened." Hence, the switch remains on for a time much longer than the FWHM of the laser pulse.

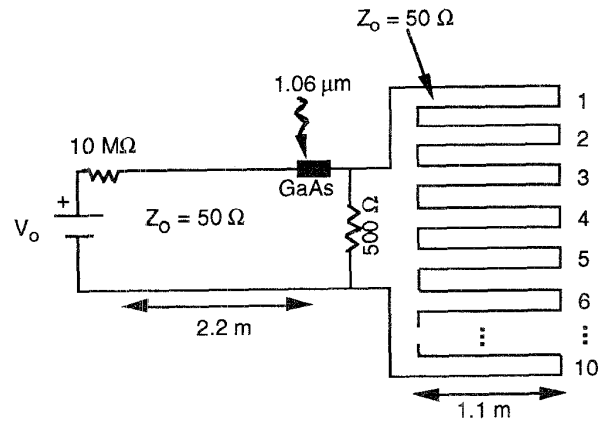

Figure 3. Inductive energy storage pulsed power system (IESPPS) with 500- $\Omega$  characteristic impedance constructed from ten 50- $\Omega$  CCTL's placed in series with floating shields.

Energy is initially stored in the open-ended (1-M $\Omega$  load) transmission line (TL) on the left which is charged to the voltage  $V_0$ . The switch is then closed by the laser trigger pulse. Subsequently, the TL on the left discharges into the CCTL's on the right. The CCTL's are charged to a high current, and, when the switch opens, the current in the CCTL's is dumped to the load. If the switch can be opened fast enough, the stored current will produce a voltage in the load which is higher than the initial charging voltage,  $V_0$ . Notice that this circuit is similar to that of Fig. 1, except that the capacitor has been replaced by an open ended charging line, the single CCTL has been replaced by ten series CCTL's, and the matched load is now 500- $\Omega$ .

#### Experiment and Computer Model

The IESPPS of Fig. 3 was treated in a computer model with the CCTL's being regarded as lumped inductances, the TL on the left taken as an equivalent lumped capacitance, and an initial charging voltage of  $V_0 = 700$ -V was assumed. Two cases are treated. In the first case, the "zero switch resistance model", the switch resistance is taken to go from infinity to zero at  $t = 0$ , and to remain zero thereafter. The result is a damped oscillation as expected for a simple RLC circuit. In this model, the switch never opens; therefore the oscillations continue until they are damped out by the load resistor. The result of the model is plotted in Fig. 4.

In the next case, the "dynamic switch resistance model" we took the switch dynamic on-resistance as a sixth order polynomial fit to the dynamic switch resistance behavior of Fig. 2. The switch opening is slow, therefore the oscillations soon become critically damped as shown in Fig. 4. Note that the magnitude of the voltage is always less than the initial voltage at  $t = 0$ .

Finally, the experimentally observed result is also presented in Fig. 4. The 3-cm long GaAs PCS and laser pulse as described above were used. An initial charging voltage of  $V_0 = 700$ -V was used for comparison with the theoretical model. We note that the

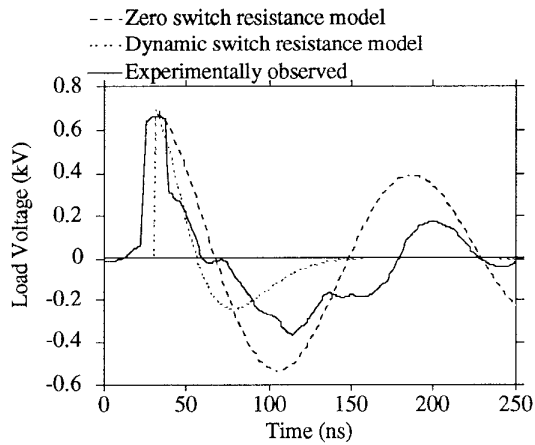

Figure 4. Computer model and experimental result of the switch behavior in the circuit of Figure 3 when operated at a charging voltage of  $V_0 = 700\text{-V}$ .

period of oscillation is closer to that predicted by the "zero switch resistance" model, and that the "dynamic switch resistance model" predicts stronger damping and a somewhat shorter period than we observe.

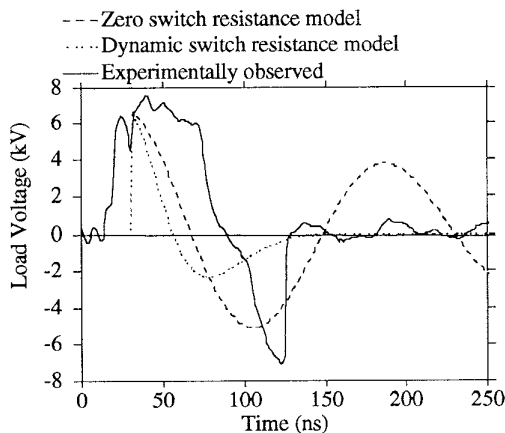

Figure 5. Computer model and experimental result of the switch behavior in the circuit of Fig. 3 when operated at a charging voltage of  $V_0 = 6.7\text{-kV}$ .

At the low charging voltage of  $V_0 = 700\text{-V}$ , the switch opens slowly, and no gain in voltage or power is observed. However, at a charging voltage of  $6.7\text{-kV}$  an output voltage pulse of  $-7.0\text{-kV}$  was reached with a corresponding peak power of  $100\text{-kW}$ . This pulse is shown in Fig. 5. Furthermore, the risetime of the pulse was less than  $20\text{-ns}$ , which is indicative of a sudden quenching of conductivity resulting in fast opening switch action.

There were some other GaAs switches which provided a significant gain in voltage and peak power when utilized in this IESPPS. One of these results is presented in Figure 6 where we

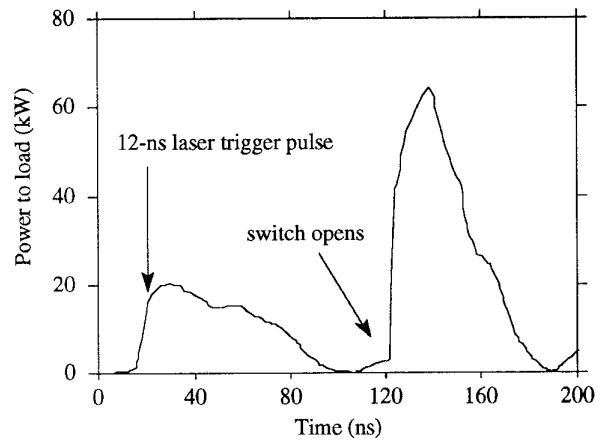

Figure 6.  $5\text{-mm}$  cube GaAs switch operated in the circuit of Fig. 3 with  $V_0 = 3.8\text{-kV}$ .

plot the instantaneous power delivered to the load. Note that the risetime of the output pulse is less than  $20\text{-ns}$ .

In order to define a power gain we compare our system to an ideal charged line pulser (CLP). The CLP consists of a charged, open ended TL connected through an ideal closing switch to a matched load. Our system consists of a CLP with the addition of an inductive energy storage element consisting of CCTL's placed in parallel with the load which is now matched to the CCTL's. The power delivered by a CLP to a matched load is:

$$P_{CLP} = \frac{V_0^2}{4R_L},$$

where  $V_0$  is the voltage to which the line is initially charged, and  $R_L$  is the matched load resistance. Thus, for the result shown in Fig. 6 with  $V_0 = 3.8\text{-kV}$  and  $P_{out} = 64\text{-kW}$  the power gain is given by:

$$G = \frac{P_L}{P_{CLP}} = \frac{64\text{ kW}}{7.2\text{ kW}} = 8.9,$$

where  $P_L$  is the power delivered to the load in the actual IESPPS circuit. Thus, we see that fast opening of the switch can occur and power gain can be achieved without using a specially designed laser as was used in the past. This is a significant result because it demonstrates that a commercially available Q-switched laser can be used without the need for pulse shaping, and the complexity of the optical driver for the switch is simplified.

### Discussion

Concerning the opening action of the PCS at high  $V_0$ , we return to Fig. 5 to make some observations about the behavior of the  $3\text{-cm}$  PCS. First, even in the ideal case of zero switch on-resistance we do not expect the amplitude of the load voltage to reach that of the initial charging voltage,  $V_0$ , other than at  $t=0$ . We are led to conclude that the switch impedance must actually be rising with a fast ( $\sim 20\text{-ns}$ ) risetime in order to produce the  $-7\text{-kV}$  pulse across the load.

Next, it is also clear that the shape of the wave form is erratic, not following the expected damped sinusoidal response of the model. Furthermore, after several hundred shots the shape of the response changes, and such fast opening action is no longer observed. This is indicative of a breakdown mechanism.

One form of breakdown which is observed in GaAs at fields as low as  $\sim 3.6$ -kV/cm is current filamentation<sup>6</sup> which has been related to the phenomenon known as "lock-on"<sup>4</sup> in closing switch work. The fast opening which we observe may be due to a quenching of current filaments due to a load-line dependence on the conditions for filamentation. We point out that this behavior is different than "lock-on" in that it manifests itself as a switch opening action rather than locking the switch closed.

### Conclusion

An inductive energy storage pulsed power system (IESPPS) operating with a GaAs photoconductive opening switch has been demonstrated. The IESPPS utilized current charged transmission lines (CCTL's) as inductive energy storage elements. A high impedance system ( $500\text{-}\Omega$ ) was used in order to give a switch on-time which was longer than the controlling laser pulse, allowing a longer time for the charging of current in the CCTL's. When operated at a high enough voltage, the switch conductivity was found to be suddenly quenched after a period of sustained conduction. This resulted in a fast enough opening time to produce an output pulse with less than 20-ns risetime, and a power gain of up to 8.9.

The advantage of this IESPPS is that a commercially available Q-switched laser can be used to control the switch. The switch can be triggered by a short pulse and no pulse shaping is required.

The mechanism responsible for the fast opening of the switch is not yet understood, but we believe that breakdown of the switch is occurring since the switch's response changes after only several hundred shots. Work continues in order to understand the mechanism responsible for the observed fast opening. Further insight may allow us to design a switch which is capable of withstanding a greater number of shots and can be used in a practical system.

### Acknowledgment

This work was funded by the Army Research Laboratory and the Strategic Defense Initiative Organization/Innovative Science and Technology, Office of Naval Research.

### References

<sup>1</sup>E.E. Funk, C. C. Kung, E. A. Chauchard, M. J. Rhee, Chi H. Lee, "Photoconductive switch-controlled inductive pulsed power system" in *High -Power Optically Activated Solid-State Switches* Arye Rosen and Fred J. Zutavern, Eds. Boston, MA: Artech House. May 1993.

<sup>2</sup>E. E. Funk, E. A. Chuachard, M. J. Rhee, and Chi H. Lee, "80-kW Inductive Pulsed Power System with a Photoconductive Semiconductor Switch," *IEEE Photonics Technology Letters*, Vol. 3, pp. 576-577, 1991.

<sup>3</sup>M. J. Rhee, T. A. Fine, and C. C. Kung, "Basic circuits for inductive energy pulsed power systems," *Journal of Applied Physics*, Vol. 67, pp. 4333-4337, 1990.

<sup>4</sup>F. J. Zutavern, G. M. Loubriel, B. B. McKenzie, M. W. O'Malley, R. A. Hamil, L. P. Schanwald, and H. P. Hjalmarson, "Photoconductive semiconductor switch recovery," in *Dig. Tech. Papers, 7th IEEE Pulsed Power Conference.*, R White and B. H. Bernstein, Eds., New York, 1989, pp. 412-417.

<sup>5</sup>E. E. Funk, P. S. Cho, C. C. Kung, E. A. Chauchard, M. J. Rhee, P.-T. Ho, J. Goldhar, and Chi H. Lee, "Recent advances in research on photoconductive power switching at the University of Maryland," *Proc. of the SPIE Conference on Optically Activated Switching II*, Vol. 1632, January 19-25, 1992.

<sup>6</sup>F. J. Zutavern, G. M. Loubriel, M. W. O'Malley, W. D. Helgeson, D. L. McLaughlin, "High gain photoconductive semiconductor switching," in *Digest of Technical Papers, Eighth IEEE International Pulsed Power Conference*, Kenneth Prestwich and Roger White, Eds., 1991, pp. 23-28.