



www.RedMountainRadio.com

Thanks for your interest in my technical paper. If you find this work to be interesting, or have additional questions, please contact me at the address below. Red Mountain Radio LLC offers professional RF, optical, and microwave design services, and problem solving.

Regards,
Eric Funk, Ph. D.
Partner, Red Mountain Radio LLC
eric@redmountainradio.com
970-325-2158 x12

The following IEEE paper is subject to copyright as noted below.

This material is presented to ensure timely dissemination of scholarly and technical work. Copyright and all rights therein are retained by authors or by other copyright holders. All persons copying this information are expected to adhere to the terms and constraints invoked by each author's copyright. In most cases, these works may not be reposted without the explicit permission of the copyright holder.

©1996 IEEE. Personal use of this material is permitted. However, permission to reprint/republish this material for advertising or promotional purposes or for creating new collective works for resale or redistribution to servers or lists, or to reuse any copyrighted component of this work in other works must be obtained from IEEE."

OPTICALLY CONTROLLED SPREAD-SPECTRUM RF DATA LINK

Eric E. Funk, Stephen E. Sadow, and L. J. Jasper, Jr.
Army Research Laboratory
2800 Powder Mill Road
Adelphi, MD 20783

Chi H. Lee
University of Maryland
Department of Electrical Engineering
College Park, MD 20742

ABSTRACT

An optically controlled spread-spectrum RF data link architecture was demonstrated. The data link used a time-hopped optical pulse train derived from a mode-locked laser to synchronize transmission and correlated reception of wideband RF pulses. This was the first demonstration of an optically controlled time-hopped RF spread-spectrum link.

Thus, we have proposed and demonstrated an optically controlled time-hopped SS link. The time-hopped link uses picosecond photoconductivity [2] to generate precisely timed ultra-wideband (UWB) RF pulses. The absence or presence of an RF pulse is used to represent a single bit. The timing of each RF pulse is controlled by a time-hopped optical trigger sequence. The time-hopped UWB RF sequence is controlled by a low bit rate PRBS.

INTRODUCTION

Spread-spectrum (SS) RF communications links are often used in applications requiring noise immunity, jam-resistance, or signal security. Conventional SS techniques [1] such as frequency-hopping or direct-sequence are used in a wide variety of wireless applications. The bandwidth of such systems is typically determined by the bit rate of the pseudo-random bit sequence (PRBS) that is used for bandwidth spreading in the transmitter and correlation in the receiver. Thus, the speed of digital electronics is expected to limit the bandwidth that is achievable.

SYSTEM ARCHITECTURE

The SS transmitter is shown in Fig. 1(a). Pulses from a laser trigger a linear (non-avalanche) photoconductor or photodiode (PD), generating jitter-free UWB electrical impulses. Each UWB impulse is amplified, filtered, and radiated by a UWB antenna.

The RF spectrum is evenly spread by controlling the laser to produce a pseudo-random optical pulse sequence. Digital information is modulated onto the pulsed UWB signal by

TH
3D

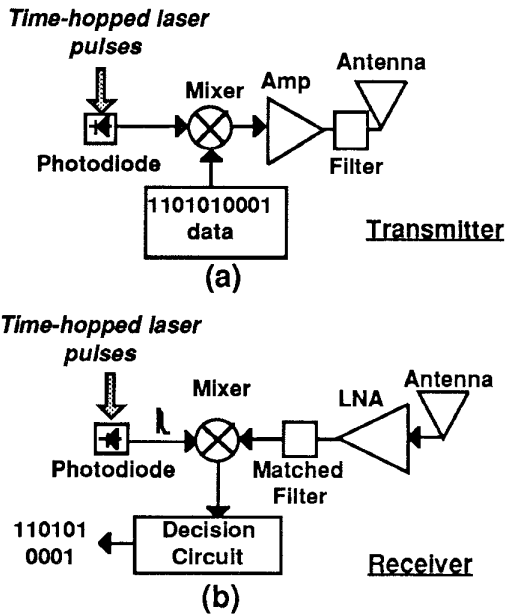

Figure 1. (a) Optically controlled spread-spectrum transmitter and (b) receiver.

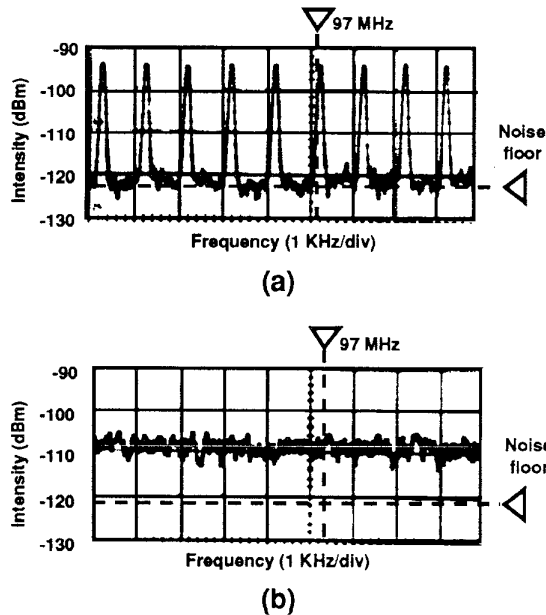

Figure 2. (a) Spectrum analyzer display of RF comb spectrum generated by 1-kHz optical pulse train triggering a photodiode with regularly spaced optical pulse interval and (b) noise like spectrum generated with time-hopped pulse interval. (Resolution bandwidth is 100 Hz.)

on/off keying in a microwave mixer.

The receiver is shown in Fig. 1(b). An incoming signal is received by a UWB antenna. The signal is amplified in a low-noise amplifier (LNA) and filtered by either a matched filter (MF) or a bandpass filter to optimize the SNR. The signal is then correlated in a microwave mixer as follows.

A pulsed laser in the receiver generates a synchronized replica of the transmitter's pseudo-random optical pulse sequence. A fast photodiode converts the optical sequence to an RF sequence which is mixed with the incoming signal. Hence, the mixer correlates the received pulse sequence with the local replica. Phase or delay locking techniques may be used to maintain synchronization of the receiver's laser. Alternately, the laser beam used to drive the transmitter may be split and used to drive the receiver if a suitable optical delay line is included.

The output of the mixer drives a decision circuit. The decision circuit uses a threshold detector after a crystal detector that converts the received RF pulses into more narrowband video pulses.

EXPERIMENT

We assembled a link to test the architecture described above. A semiconductor diode-pumped Nd:YLF mode-locked laser/regenerative amplifier was used as a 100-ps full width at half maximum optical pulse source.

Trigger signals to the Pockels Cell of the laser's regenerative amplifier were controlled to produce a time-hopped, amplified optical pulse sequence with an average repetition rate of 1 kHz. The time-hopped sequence was derived from a shift-register maximal length 32,767-bit PRBS generator. The PRBS generator was clocked to the laser's acousto-optic modulator drive oscillator.

The time-hopped optical pulses were attenuated and used to trigger Si PIN photodiodes (PDs) in both the transmitter (70 nJ/pulse) and receiver (35 nJ/pulse). The optical pulse train was fed to the remote receiver through multimode optical fiber. The triggered PDs produced baseband electrical pulses with sub-nanosecond rise-time.

The time-hopping code produced an RF signal that appeared noise-like. The spectrum of the signal from the transmitter's PD was monitored as shown in Fig. 2. When triggered by a regularly spaced 1-kHz optical pulse train, the PD produces a comb spectrum. However, when the optical pulse train is time-hopped (with an average repetition frequency of 500 Hz), the PD signal produces what appears to be an increase in the level of ambient noise, as required for SS signal security.

In the transmitter, the time-hopped RF pulse train from the PD was on/off keyed by the serial data to be sent. The serial data were synchronized to the laser pulse sequence with an average bit rate of 500 b/s. The keyed RF pulse train was amplified by a wide-band (3 GHz) RF amplifier, filtered in a 545-MHz high-pass filter, and radiated by an electrically short conical monopole antenna (CMA) [3].

We used the setup of Fig. 1(b) to receive the signal. The receiver used a short CMA receiving antenna placed 1.1 m from the transmitting antenna. The received signal was amplified by a wideband (4 GHz) amplifier with a 6-dB noise figure and filtered by a 900-MHz high-pass filter. The optical signal to the receiver was delayed such that the base-band electrical pulses from the receiver's PD were coincident with the incoming RF pulses from the amplifier. A 4.3-GHz bandwidth mixer was used for correlation. The correlated signal with ~ 1.4 GHz center frequency is shown in Fig. 3.

A decision circuit was used that consisted of a crystal detector driving a threshold detector. The signal from the threshold detector was monitored on an oscilloscope and was repeatedly compared to 20-ms-long portions of the digital sequence that was sent. No errors were

found. In the future we will repeat the experiment with a quantitative measurement of bit error rate (BER); however, we expect that the BER will be at least comparable with electronic SS systems.

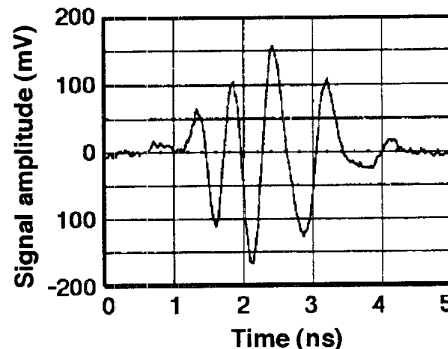

Figure 3. Wide-band signal following correlation in the receiver's mixer.

CONCLUSION

Picosecond photoconductivity provides an ideal means of producing SS, RF signals with bandwidths that exceed those of present day SS links. The precise control of timing offered by optical control lends itself to a time-hopped spread spectrum system. We have demonstrated that such a system could be developed using mostly off-the-shelf components. In the future we plan to interface our system with a terminal node controller for communications between computers, test the anti-jamming capabilities, and use Q-switched semiconductor lasers [4] in both the transmitter and receiver. Bandwidths of tens of gigahertz can also be achieved by using a faster photo-detector and higher-speed electronics. The precise control of timing will also allow multiple transmitter/receiver units to be phased together in a true-time delay beam-steering array [5].

ACKNOWLEDGEMENT

The High-Power Microwave Technology Office at the Army Research Laboratory is gratefully acknowledged for partial funding of this work.

REFERENCES

- [1] Robert C. Dixon, *Spread Spectrum Systems*, New York: John Wiley and Sons, 1984.
- [2] Chi H. Lee, *Picosecond Optoelectronic Devices*, Orlando, FL: Academic Press, 1984.
- [3] C. W. Harrison, Jr., and C. S. Williams, Jr., "Transients in wide-angle conical antennas," *IEEE Trans. Antennas Propaga.*, Vol. 13, pp. 236-246, 1965.
- [4] S. H. Yang, B. J. Thedrez, S. E. Saddow, Y. Q. Liu, and C. H. Lee, "Cross-correlation measurement of the turn-on delay and pulsewidth of a Q-switched two-section semiconductor laser," *IEEE Photonics Tech. Lett.*, Vol. 5, pp. 1365-1368, 1993.
- [5] Eric E. Funk, Stephen E. Saddow, Louis J. Jasper, Jr., and Chi H. Lee, "Coherent power combining of ultra-wideband radiation in free-space," *1995 IEEE MTT-S Digest*, pp. 1299-1302, 1995.